

**Honeywell**

# **CK67 Series Accessories**

Universal and Standard

---

**User Guide**

---

## Disclaimer

Honeywell International Inc. (“HII”) reserves the right to make changes in specifications and other information contained in this document without prior notice, and the reader should in all cases consult HII to determine whether any such changes have been made. HII makes no representation or warranties regarding the information provided in this publication.

HII shall not be liable for technical or editorial errors or omissions contained herein; nor for incidental or consequential damages resulting from the furnishing, performance, or use of this material. HII disclaims all responsibility for the selection and use of software and/or hardware to achieve intended results.

This document contains proprietary information that is protected by copyright. All rights are reserved. No part of this document may be photocopied, reproduced, or translated into another language without the prior written consent of HII.

Copyright ©2024 Honeywell Group of Companies. All rights reserved.

Web Address: [automation.honeywell.com](https://automation.honeywell.com)

## Trademarks

Other product names mentioned in this manual may be trademarks or registered trademarks of their respective companies and are the property of their respective owners.

## Patents

For patent information, see [www.hsmpats.com](https://www.hsmpats.com).

# TABLE OF CONTENTS

Customer Support .....	iii
Technical Assistance .....	iii
Product Service and Repair .....	iii
Limited Warranty .....	iii
<b>Chapter 1 - Introduction .....</b>	<b>1</b>
List of Universal and Booted Accessories .....	2
Agency Models .....	2
Legacy Accessories .....	2
<b>Chapter 2 - Protective Boot.....</b>	<b>5</b>
Out of the Box .....	5
Attach the Protective Boot.....	6
Remove Protective Boot.....	6
<b>Chapter 3 - Scan Handle .....</b>	<b>7</b>
Features .....	7
Out of the Box .....	8
Attach Scan Handle.....	8
Scan a Bar Code.....	9
<b>Chapter 4 - Universal Dock Home Base and Ethernet Home Base .....</b>	<b>11</b>
Features .....	11
Out of the Box .....	12
Connect Power .....	12
Charge the Battery Pack.....	13

Replace the Battery Cup .....	14
<b>Chapter 5 - Universal Charge Base and Net Base .....</b>	<b>17</b>
Features .....	17
Out of the Box.....	18
Connect Power .....	18
Charge the Battery Pack .....	19
<b>Chapter 6 - Universal Dock Cups.....</b>	<b>21</b>
Out of the Box.....	21
Replacing a Universal Cup.....	22
<b>Chapter 7 - Mount a Charging Dock.....</b>	<b>25</b>
Mount a Charging Dock.....	25

# Customer Support

## Technical Assistance

To search our knowledge base for a solution or log into the Technical Support Portal and report a problem, go to [honeywell.com/PSTechnicalsupport](https://honeywell.com/PSTechnicalsupport).

## Product Service and Repair

Honeywell International Inc. provides service for all of its products through service centers throughout the world. Go to [automation.honeywell.com](https://automation.honeywell.com), and then select **Support > Productivity Solutions** to find a service center near you or to get a Return Material Authorization number (RMA #) before returning a product.

## Limited Warranty

For warranty information, go to [automation.honeywell.com](https://automation.honeywell.com) and select **Support > Productivity Solutions > Warranties**.



# INTRODUCTION

Honeywell offers a full range of universal and boot-compatible accessories for the CK67 mobile computer, including:

- Protective Boot ([page 5](#))
- Scan Handle ([page 7](#))
- Home Bases and Ethernet Bases for one device and one battery (see [page 11](#))
- Charge and Ethernet Bases for up to four devices (see [page 17](#))
- Replacement Cups for Universal Bases (see [page 21](#))

**Note:** *Throughout this manual, all versions of the mobile device are referred to as the CK67 computer unless information is specific to a particular model.*



**Caution:** We recommend the use of Honeywell accessories and power adapters. Use of any non-Honeywell accessories or power adapters may cause damage not covered by the warranty.

**Mise en garde:** Il est recommandé d'utiliser les périphériques, les cordons d'alimentation et les adaptateurs secteur conçus par Honeywell. L'utilisation de tout périphérique, cordon d'alimentation ou adaptateur secteur d'une autre marque est susceptible de provoquer des dommages non couverts par la garantie.



**Caution:** Make sure that all components are dry prior to using the computers and batteries with accessories. Using wet components may cause damage not covered by the warranty.

**Mise en garde:** Assurez-vous que tous les composants sont secs avant de connecter les terminaux/batteries à des périphériques. L'insertion de composants humides risque de provoquer des dommages non couverts par la garantie.

# List of Universal and Booted Accessories

Accessory	Part Number	Use With
<b>Protective Boot</b>	CK67-PB-1	CK67
<b>Scan Handle</b> Attaches to the mobile computer to provide handle grip and pull-trigger for barcode scanning.	CK67-SCH	CK67 with or without boot
<b>Universal Home Base</b> Charge and communication base for one mobile computer and one spare battery. Base has one USB client connector (Type B).	CK67-HB-UVN	CK67 without boot
	CK67-HB-UVB	CK67 with boot
<b>Universal Ethernet Home Base</b> Charge and communication base for one mobile computer and one spare battery. Base has one Ethernet connector and one USB client connector (Type B).	CK67-EB-UVN	CK67 without boot
	CK67-EB-UVB	CK67 with boot
<b>Universal Charge Base</b> Charges up to four mobile computers.	CK67-CB-UVN	CK67 without boot
	CK67-CB-UVB	CK67 with boot
<b>Universal Ethernet (Net) Base</b> Holds four mobile computers and is both a charge and communication base with two RJ45 Ethernet ports.	CK67-NB-UVN	CK67 without boot
	CK67-NB-UVB	CK67 with boot
<b>Universal Cups</b> Replacement cups for universal bases.	CK67-UCP-N	CK67 without boot
	CK67-UCP-B	CK67 with boot
<b>Universal Battery Cup</b> Replacement battery cup for Universal Home Bases and Ethernet Home Bases.	CK6X-UCP-BATTHEB	CK67 battery

## Agency Models

CT40-HB, CT40-EB, CK65-CB, CK65-NB

## Legacy Accessories

The following legacy CK65/CK3 charging accessories are compatible with CK67 mobile computers:

CK65/CK3 Accessory	Part Number	Use With
<b>CK65 Universal Charge Base</b> Charges up to four devices.	CK65-CB-UVN	CK67 without boot



<b>CK65/CK3 Accessory</b>	<b>Part Number</b>	<b>Use With</b>
<b>CK65 Universal Net Base</b> Provides Ethernet connectivity and power for up to four devices.	CK65-NB-UVN	CK67 without boot
<b>AD20 Single Dock</b> Powers a device and charges a spare battery separately. Also provides client and host USB connectivity.	871-228-201, 871-228-301	CK67 without boot
<b>AC20 Quad Battery Charger</b> Charges up to four batteries at a time.	871-230-101, 871-230-301	CK67 battery

User documentation for CK65/CK3 accessories is provided online at [automation.honeywell.com](http://automation.honeywell.com).

For a complete list of accessories for your mobile computer and their part numbers see the *Accessory Guide* for your device, available for download at [automation.honeywell.com](http://automation.honeywell.com).

Contact your local sales representative for ordering information.



# PROTECTIVE BOOT

Honeywell offers the following protective boot for use with a CK67:

- CK67-PB-1

Honeywell also offers a series of boot-compatible communication and charge accessories that do not require you to remove the protective boot from the device before use.

To learn more, see [List of Universal and Booted Accessories](#) on page 2.

## Out of the Box

Make sure that your shipping box contains the following:

- Protective Boot (CK67-PB-1)

If any items are missing or appear damaged, contact your Customer Account Representative. Keep the original packaging in the event that you need to return an item or if you want to store it while not in use.

# Attach the Protective Boot

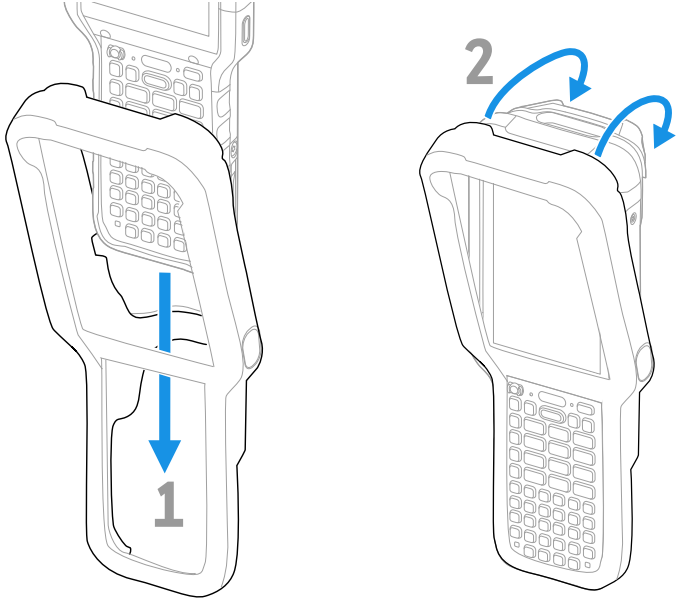

# Remove Protective Boot

**Note:** The boot does not need to be removed for battery replacement.  
Routinely inspect the protective boot for damage and replace if needed.

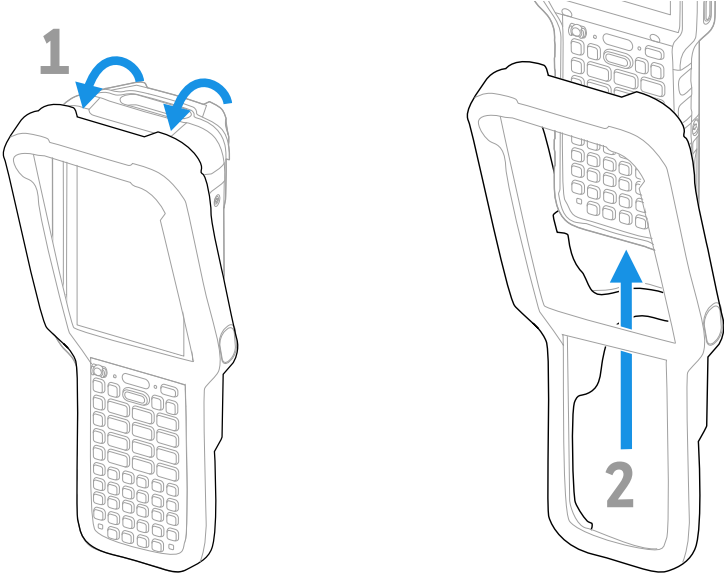

## SCAN HANDLE

A scan handle attaches to the mobile computer to provide a handle grip and pull-trigger for barcode scanning. Honeywell offers the following scan handle for the CK67 Series:

- CK67-SCH for use with a CK67 with or without a boot attached.

## Features

## CK67-SCH

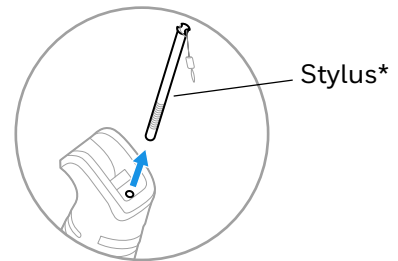
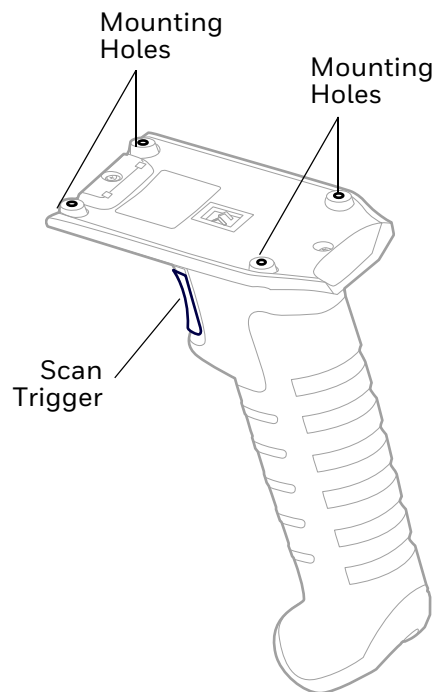

\*For information on ordering a replacement stylus, see the Accessory Guide for your device, available for download at [automation.honeywell.com](http://automation.honeywell.com).

# Out of the Box

Make sure that your shipping box contains the following:

- Scan Handle (CK67-SCH)
- M2.5 x 7 Screws (4)

If any items are missing or appear damaged, contact your Customer Account Representative. Keep the original packaging in the event that you need to return an item or if you want to store it while not in use.

## Attach Scan Handle

The CK67-SCH is compatible with a CK67 with or without a protective boot attached.

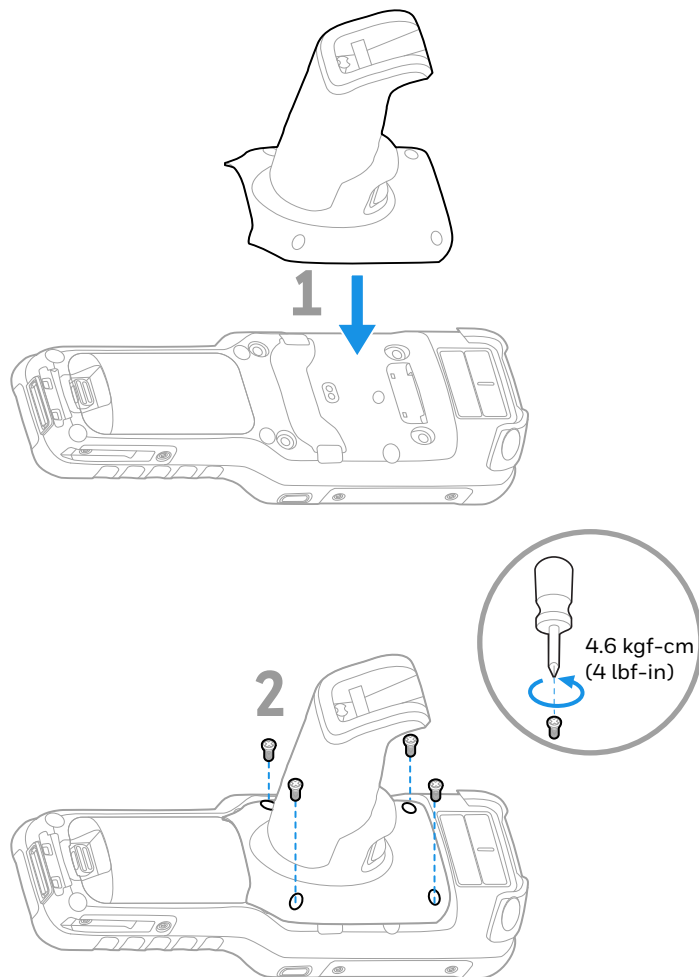

# Scan a Bar Code

Press the trigger on the handle to scan a bar code.







# UNIVERSAL DOCK HOME BASE AND ETHERNET HOME BASE

A Home Base is a charge/communication base for one mobile computer and one spare battery. The Home Base has one USB client connector (Type B).

An Ethernet Home Base is also a charge/communication base for one mobile computer and one spare battery. However, the Ethernet Base also has an Ethernet connector as well as a USB client connector.

**Note:** *Ethernet communication is not supported when a USB cable is connected to the Ethernet base and a host device (e.g., laptop or desktop computer).*

The CK67-HB-UVB Universal Home Base and CK67-EB-UVB Universal Ethernet Base are boot-compatible. The CK67-HB-UVN Universal Home Base and CK67-EB-UVN Universal Ethernet Base must be used with a computer without a boot attached. Universal bases have removable cups that can be replaced. (See [Universal Dock Cups](#) on page 21.) These bases also have removable battery cups (see page 14).

## Features

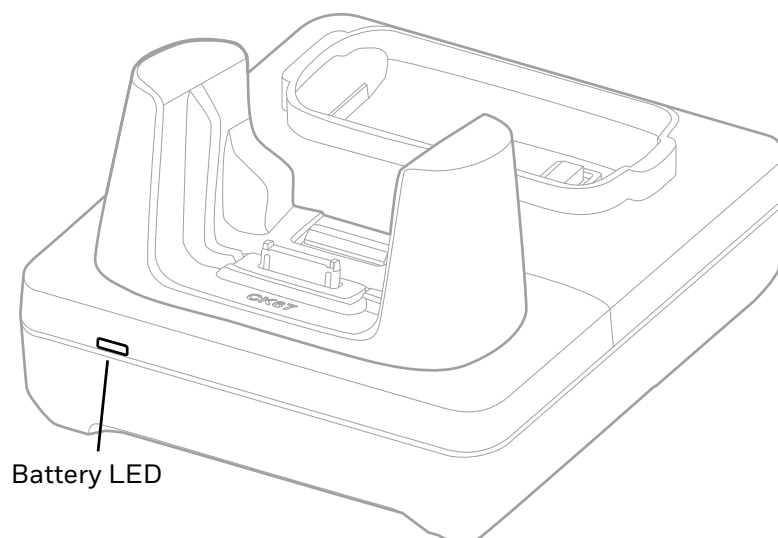

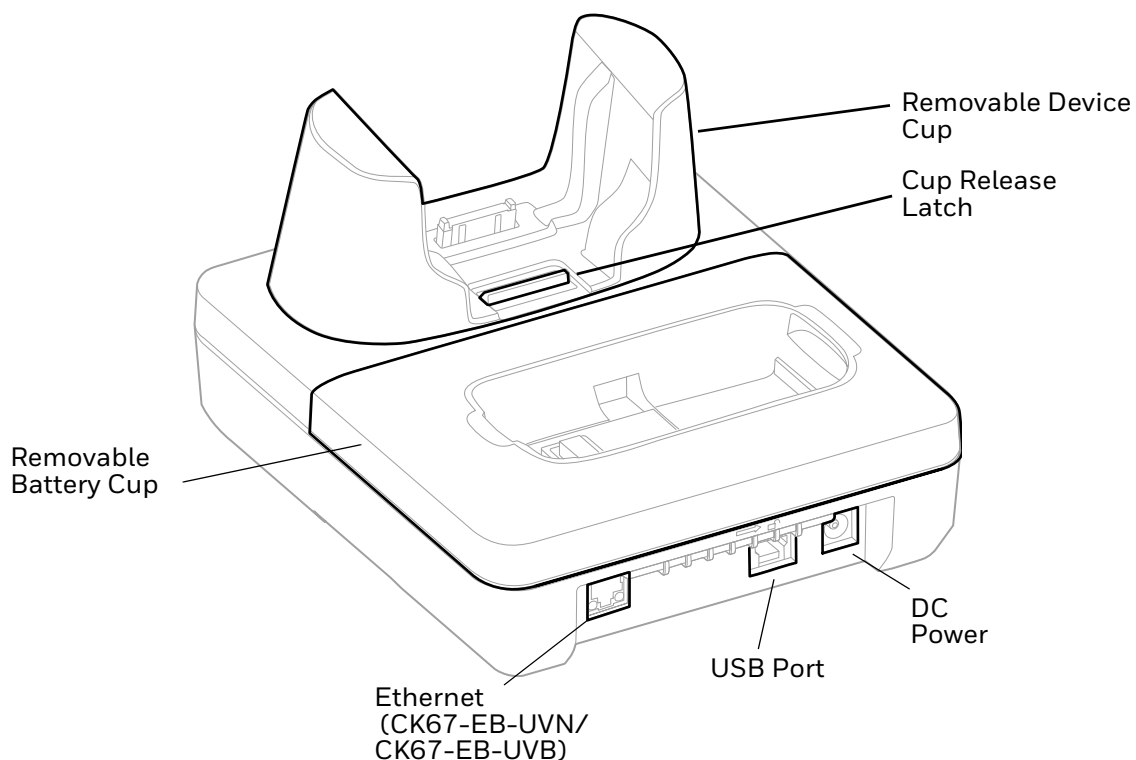

## Out of the Box

Make sure that your shipping box contains these items:

- Home Base (CK67-HB-UVN/CK67-NB-UVB) or Ethernet Home Base (CK67-EB-UVN/CK67-EB-UVB)
- Power supply
- Power cord (if purchased)
- Product documentation

If any items are missing or appear damaged, contact your Customer Account Representative. Keep the original packaging in the event that you need to return an item or if you want to store it while not in use.

## Connect Power

Use only a UL Listed power supply that has been qualified by Honeywell with an output rated at 12VDC and 3A. The power supply input rating is 90-264 VAC, 50/60 Hz. The operating temperature is -10 °C to 50 °C (14 °F to 122 °F). The maximum output of the base is 5VDC/2A.

1. Plug the power cord into the power supply.
2. Plug the power supply cable into the power connector on the back of the base.

3. Plug the power cord into a standard wall outlet.

## Charge the Battery Pack

Insert the computer into the Home Base (CK67-HB-UVN, CK67-HB-UVB) or Ethernet Home Base (CK67-EB-UVN, CK67-EB-UVB). The unit will not charge unless a battery is installed.

### CK67-HB-UVN/CK67-EB-UVN

Mobile computer  
without protective boot

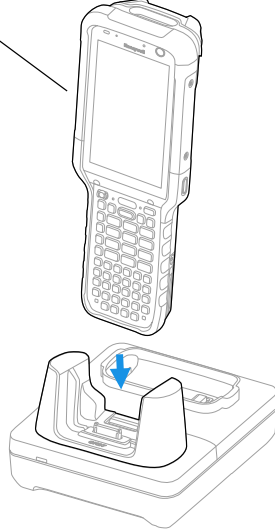

### CK67-HB-UVB/CK67-EB-UVB

Mobile computer  
with protective boot

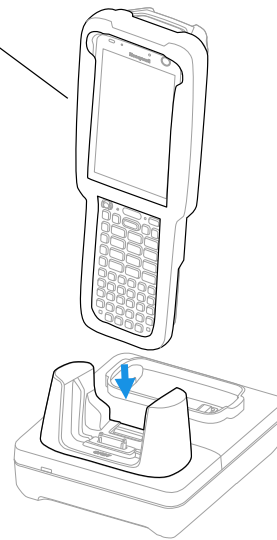

You can also insert a battery pack into the Home Base for charging.

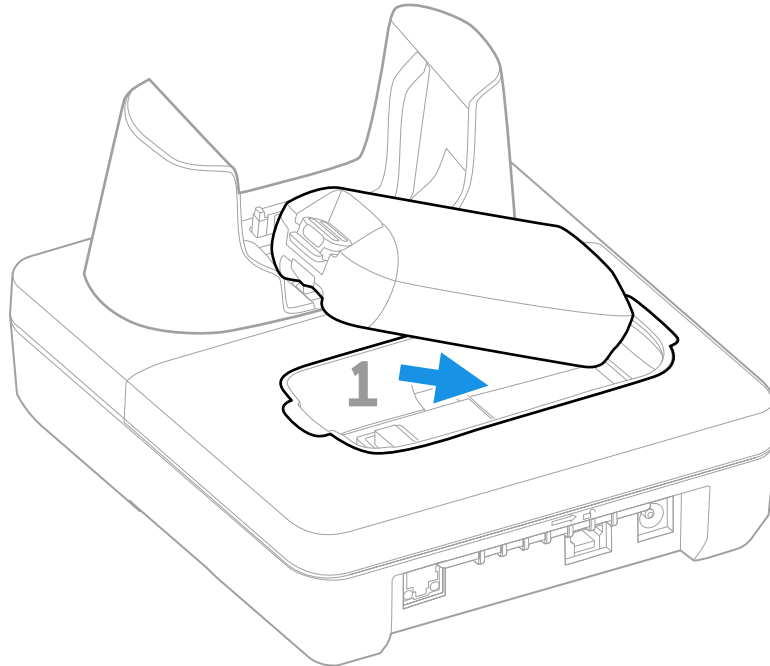

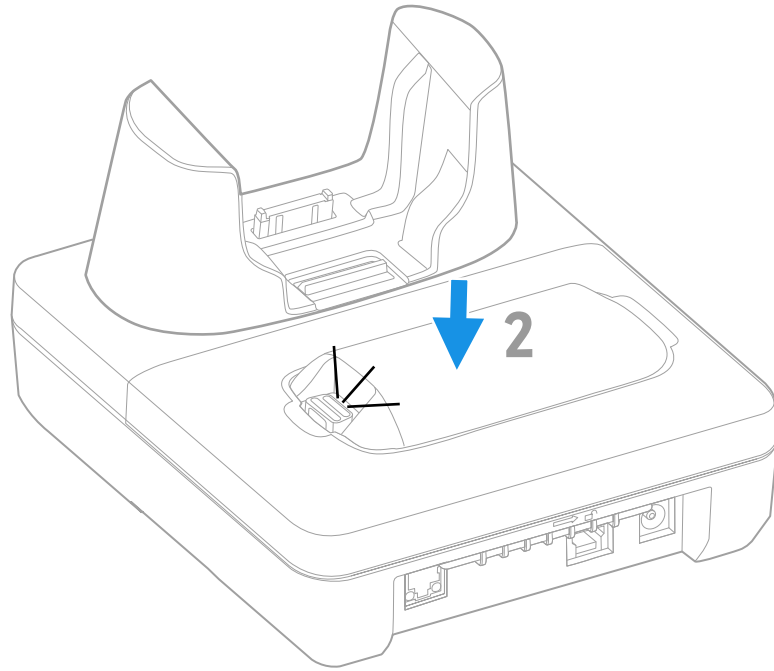

## Replace the Battery Cup

The CK67 Home Base and Ethernet Home Base have a replaceable battery cup (CK6X-UCP-BATTHEB).



**Caution:** Keep the base flat to avoid dropping the battery cup.

1. Remove all cables to allow clear access to the latch.
2. While holding the battery cup latch to the right, lift the back of the cup.

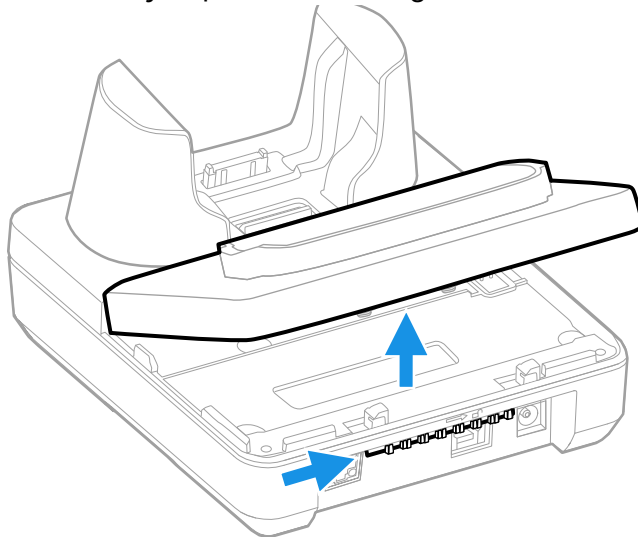

3. Release the latch and lift the old cup out of the base.

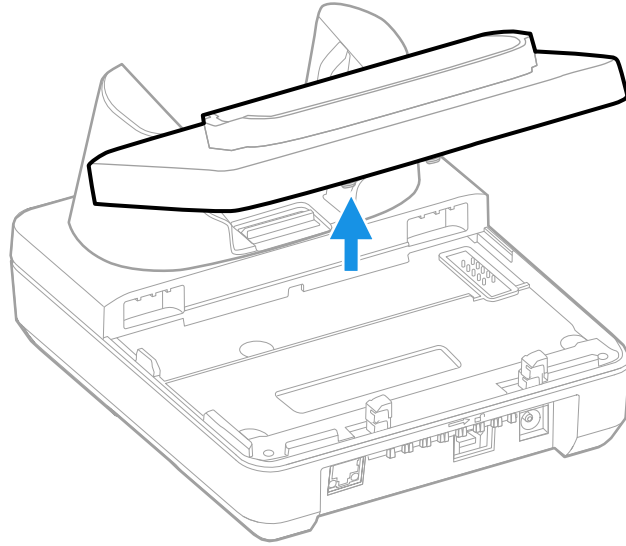

4. Insert the new cup tilted slightly towards the front of the base.

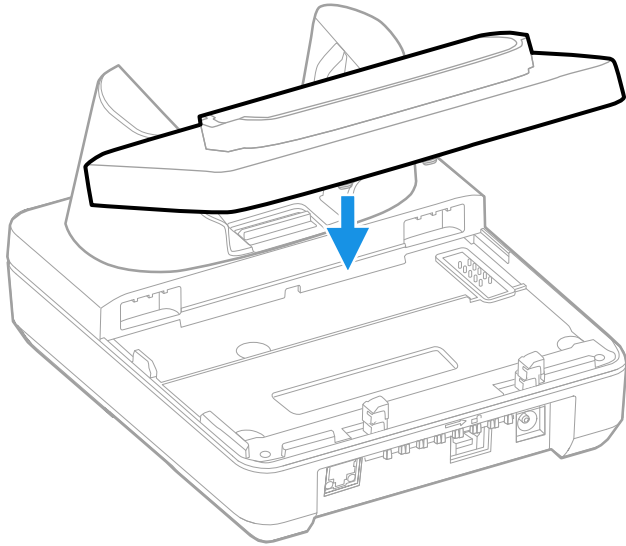

5. While holding the latch to the right, push the back of the cup into the base until it snaps in.

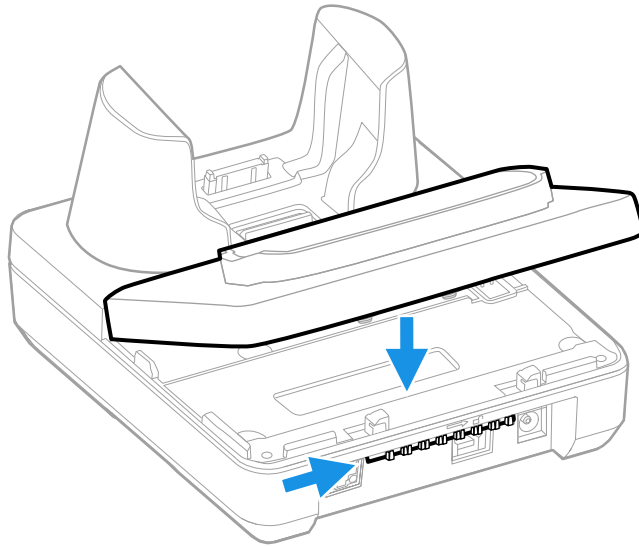

6. Release the latch.

## Status LED

LED	Status	Description
Battery	Solid Green	The battery is connected to external power and is fully charged.
	Solid Amber	The battery is connected to external power and is charging.
	Solid Red	There is a battery charging fault, such as over-temperature.

# UNIVERSAL CHARGE BASE AND NET BASE

Universal Dock Charge Bases CK67-CB-UVN and CK67-CB-UVB charge up to four mobile computers. Model CK67-CB-UVB is boot compatible.

Ethernet (Net) Bases CK67-NB-UVN and CK67-NB-UVB hold four mobile computers and function as both charge and communication bases, with two RJ45 Ethernet ports. Model CK67-NB-UVB is boot compatible.

Universal bases CK67-CB-UVN, CK67-CB-UVB, CK67-NB-UVN and CK67-NB-UVB have removal cups that can be replaced. (See [Universal Dock Cups](#) on page 21.)

## Features

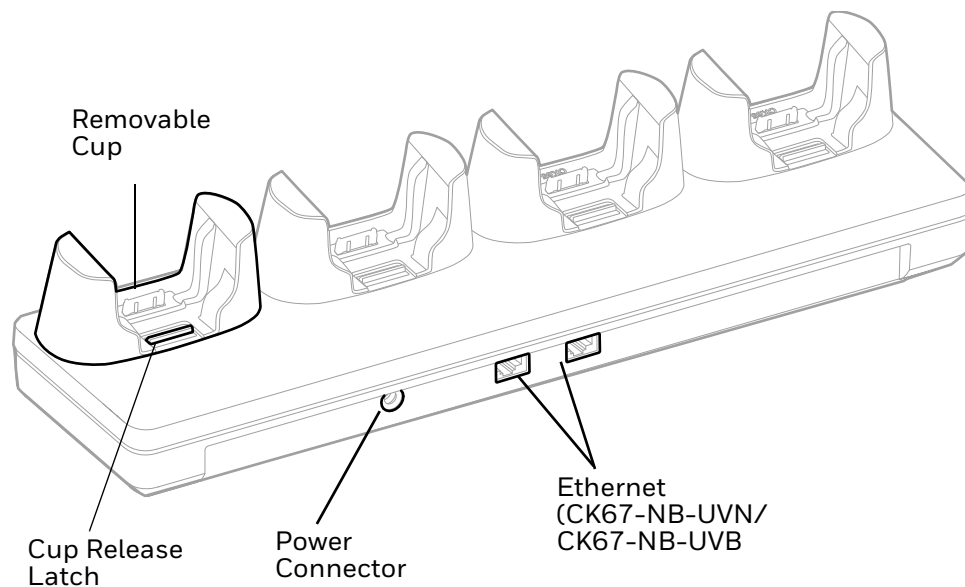

# Out of the Box

Make sure your shipping box contains these items:

- Charge Base (CK67-CB-UVN or CK67-CB-UVB) or Ethernet Base (CK67-EB-UVN or CK67-EB-UVB)
- Power supply
- Power cord (if purchased)
- Product documentation

If any items are missing or appear damaged, contact your Customer Account Representative. Keep the original packaging in the event that you need to return an item or if you want to store it while not in use.

## Connect Power

Use only a UL Listed power supply which has been qualified by Honeywell with an output rated at 12V/7A. The power supply input rating is 100-240 VAC, 50/60 Hz. The operating temperature is -10 °C to 50 °C (14 °F to 122 °F).

1. Plug the power cord into the power supply.
2. Plug the power supply cable into the power connector on the back of the charger.
3. Plug the power cord into a standard wall outlet.



# Charge the Battery Pack

- Insert one to four CK65s with battery pack inserted into the Charge Base or Net Base.

## CK67-CB-UVN/CK67-NB-UVN

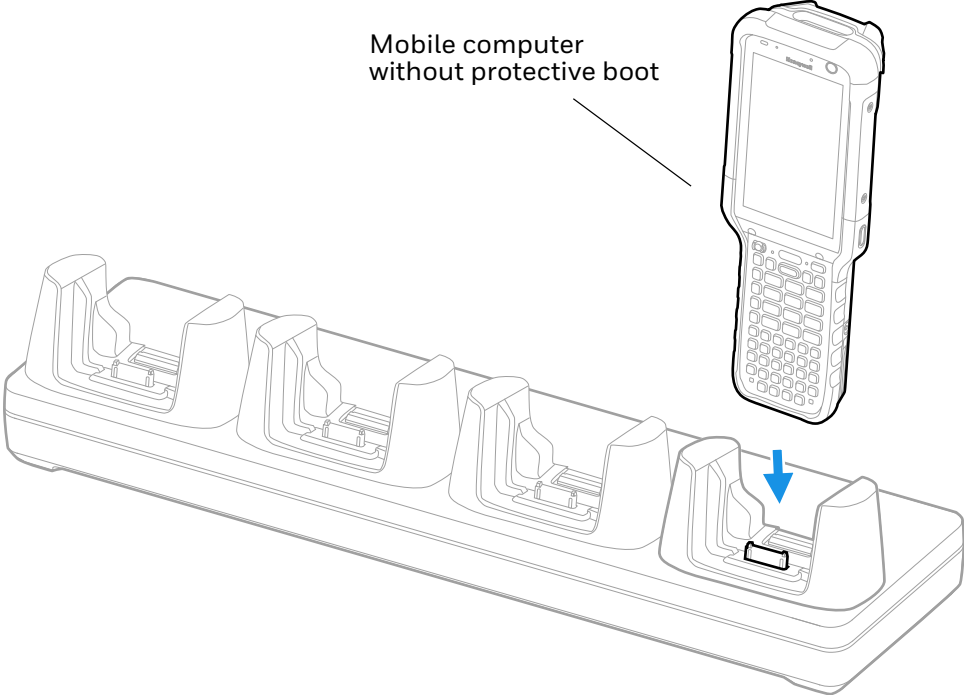

## CK67-CB-UVB/CK67-NB-UVB

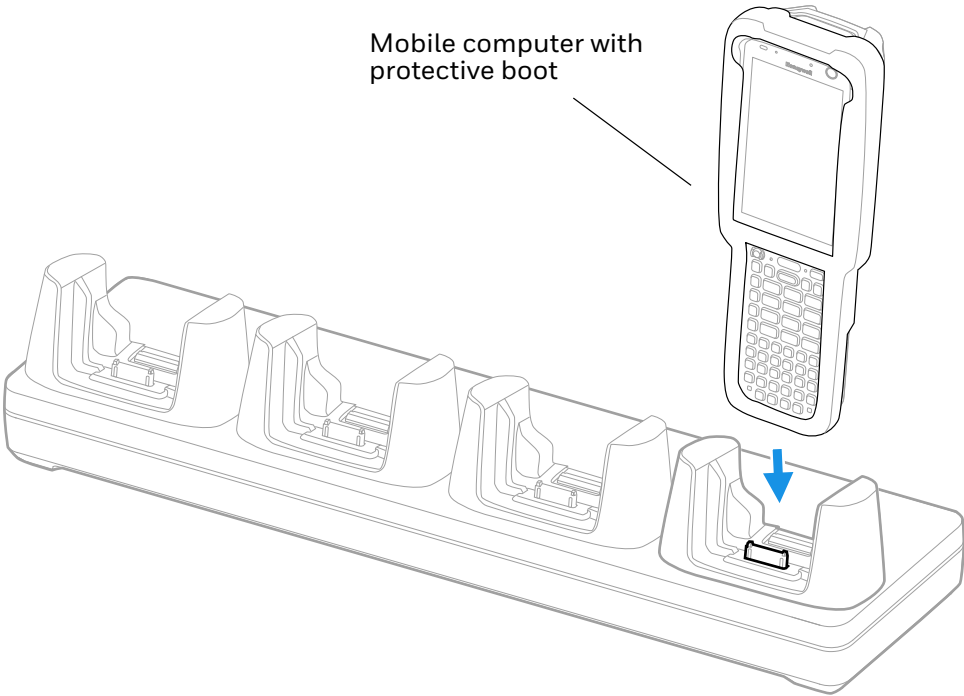



# UNIVERSAL DOCK CUPS

Universal Bases have removable cups that can be replaced with Universal Cups CK67-UCP-N and CK67-UCP-B.

CK67-UCP-N is for use with a CK67 computer without a boot. CK67-UCP-B must be used with a CK67 computer with a boot attached.

For more information about the universal docks for CK67 computers, see:

- [Universal Dock Home Base and Ethernet Home Base](#) (page 11)
- [Universal Charge Base and Net Base](#) (page 17)

## Out of the Box

Make sure that your shipping box contains these items:

- Universal Cup (CK67-UCP-N or CK67-UCP-B)

If any of these items are missing or appear damaged, contact your Customer Account Representative. Keep the original packaging in the event that you need to return the cup or if you want to store it while not in use.

# Replacing a Universal Cup

**Note:** The Universal Charge Base is shown in the instructions below for illustration purposes. The steps for removing and inserting a cup are the same for all universal bases.

1. Push the latch towards the front of the base.

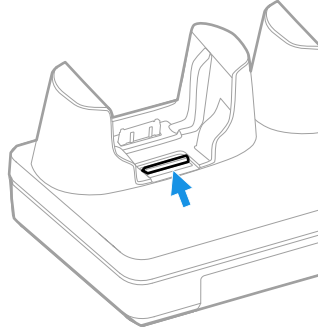

2. Tilt the back of the cup upwards.

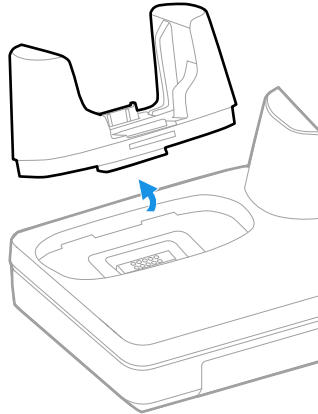

3. Lift the old cup out of the base.

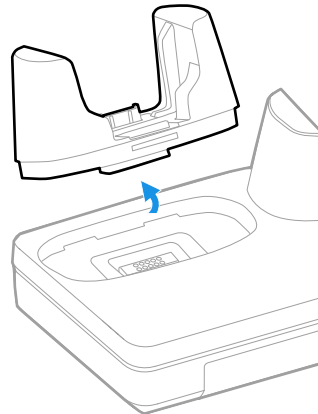

4. Insert the new cup tilted slightly towards the front of the base.

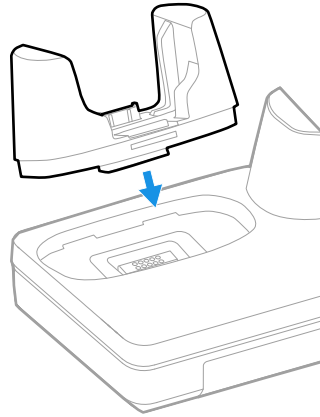

5. Push the cup into the base until it snaps in.

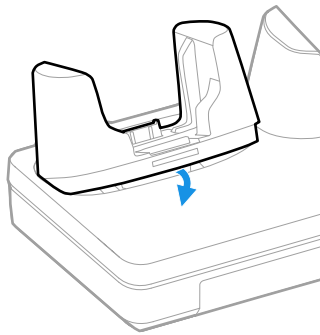



# MOUNT A CHARGING DOCK

## Mount a Charging Dock

You can mount CK67 Series charge docks on a flat, horizontal surface such as a desktop or workbench with an optional DIN rail.

Mounting hardware required:

- DIN rail
- 3/16-inch diameter x 5/8-inch long pan head screw
- 1/2-inch OD x 7/32-inch ID x 3/64-inch thick washer
- 3/16-inch diameter nut

**Note:** A Charge Base is shown in the instructions below for illustration purposes. The mounting steps are the same for all CK67 Series docks and chargers.

1. Slide the DIN rail into the slot on the bottom.

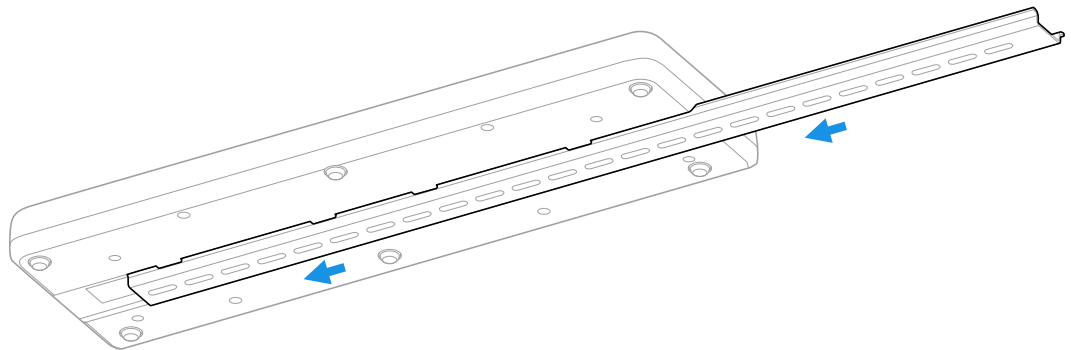

2. Secure the DIN rail to the flat surface with the hardware.

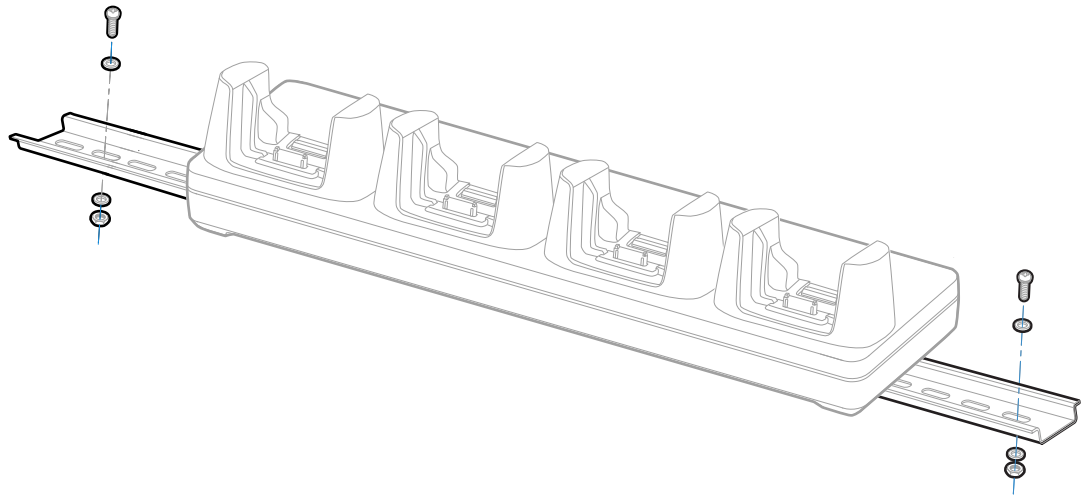

**Note:** Charging cup appearance may differ depending on model.





Honeywell  
855 S. Mint Street  
Charlotte, NC 28202

[automation.honeywell.com](https://automation.honeywell.com)